

Longitudinal & Lateral Seismic Clamp Fig. AF775

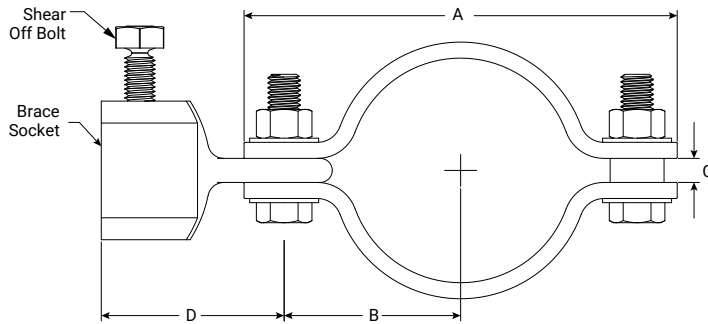
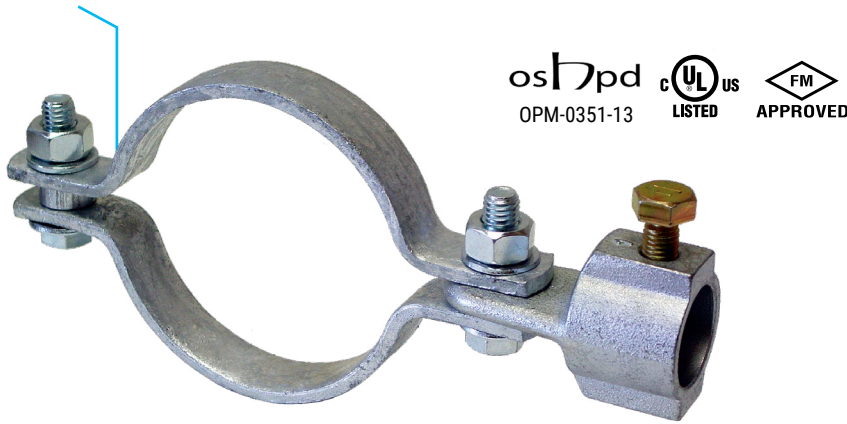

Material Specifications

Size Range:
Flange Thickness: 2 1/2" – 8"
Flange Widths: 1" – 1 1/4"

Material
Carbon Steel with a Ductile Iron Socket

Finish
Plain
Electro-Galvanized per ASTM B633

Service
A seismic longitudinal & lateral brace designed to connect a brace member to the service pipe. The AF775 rigidly braces steel piping systems subjected to horizontal and vertical seismic loads.

Approvals
cULus Listed (ANSI/UL 203a), FM Approved (FM 1950-13), & OSHPD (OPM-0351-13). Complies with NFPA 13, ASCE 7, IBC, & MSS SP-127 bracing requirements.

Features
The set screw provides a visual indication that proper installation has been achieved.

Ordering
Specify figure number, service pipe size, brace size, finish, and description.

FIG. AF775 Dimensions, Weight and Installation Torque

Brace Size	A	B	C	D	Socket Depth	Weight per Brace Size		Installation Torque
						1" (DN25)	1 1/4" (DN25)	
2 1/2"	6 in	2 3/8 in				2.19 lbs	2.54 lbs	80 ft-lbs
DN65	6 1/8 in	2 1/2 in				2.25 lbs	2.60 lbs	
3" (DN80)	6 3/4 in	2 3/4 in	3/8 in			2.36 lbs	2.71 lbs	100 ft-lbs
4" (DN100)	8 1/2 in	3 1/2 in					2.62 lbs	
DN125	9 1/2 in	4 in		2 7/8 in	3 in	1 3/8 in	3.74 lbs	4.09 lbs
5"	9 1/2 in	4 in						
DN150	11 3/8 in	4 7/8 in				6.32 lbs	6.67 lbs	120 ft-lbs
6"	11 1/2 in	4 7/8 in	1 in			6.32 lbs	6.67 lbs	
DN200	13 3/8 in	6 in					7.42 lbs	7.77 lbs
8"	13 3/4 in	6 in				7.42 lbs	7.77 lbs	



PROJECT INFORMATION	APPROVAL STAMP
Project:	Approved
Address:	Approved as noted
Contractor:	Not approved
Engineer:	Remarks:
Submittal Date:	
Notes 1:	
Notes 2:	

Longitudinal & Lateral Seismic Clamp Fig. AF775

FIG. AF775 cULus Listing per ANSI/UL 203a (ASD)

Service Pipe Size	Service Pipe	Longitudinal & Lateral Horizontal Load Rating at Brace Angle			
		30°-44°	45°-59°	60°-90°	Listed
2½"	Sch. 10 Sch. 40				
3" (DN80)	Sch. 10 Sch. 40	340 lbf (1.65 kN)	480 lbf (2.14 kN)	588 lbf (2.62 kN)	680 lbf (3.02 kN)
4" (DN100)	Metric Pipe				
5"	Sch. 10 Sch. 40	545 lbf (2.42 kN)	770 lbf (3.43 kN)	943 lbf (4.2kN)	1090 lbf (4.85 kN)
6"	Sch. 10 Sch. 40				
8"	0.188" Wall Sch. 40	685 lbf (3.05 kN)	968 lbf (4.31kN)	1186 lbf (5.28kN)	1370 lbf (6.09kN)

- 1) Brace Angles are determined from Vertical
- 2) Sch. 10 Load Ratings may be used for any thicker wall pipe of the same diameter.
- 3) Listed load ratings reduced for angle ranges in accordance with NFPA 13–2019 Table 18.5.2.3.
- 4) Load Ratings reflect 1" (DN25) – 1¼" (DN32) brace members. See table below for listed brace members.
- 5) Minimum safety factor of 2.2 in accordance with NFPA 13–2019 Section A.18.5.2.3.

FIG. AF775 cULus Listing per UL 203a (ASD) for NFPA 13-2016 Editions or Earlier

UL's current Listings are predicated on installation in accordance with the latest edition of NFPA 13. The 2016 and earlier editions of NFPA 13 referenced a minimum safety factor of 1.5 for the load rating as compared to 2.2 for the current edition. The load ratings noted in this table are consistent with the historical cULus Listings that were evaluated to the requirements of UL 203A, Outline of Investigation for Sway Brace Devices for Fire Sprinkler System Piping, based upon a minimum safety factor of 1.5 in accordance with the earlier editions of NFPA 13. The load ratings based upon the 2016 or earlier editions of NFPA 13 should only be used where approved by the Authority Having Jurisdiction (AHJ).

Service Pipe Size	Service Pipe	Longitudinal & Lateral Horizontal Load Rating at Brace Angle			
		30°-44°	45°-59°	60°-90°	Listed
2½"	Sch. 10 Sch. 40				
DN65	Metric Pipe	500 lbf (1.65 kN)	707 lbf (3.15 kN)	865 lbf (3.85 kN)	1000 lbf (4.45 kN)
3" (DN80)	Sch. 10 Sch. 40				
4" (DN100)	Metric Pipe				
DN125	Sch. 10 Sch. 40				
5"	Sch. 10 Sch. 40	800 lbf (3.56 kN)	1131 lbf (5.03 kN)	1385 lbf (6.16 kN)	1600 lbf (7.12 kN)
DN150	Metric Pipe				
6"	Sch. 10 Sch. 40				
DN200	Metric Pipe	1007 lbf (4.48 kN)	1425 lbf (6.34 kN)	1744 lbf (7.76 kN)	2015 lbf (8.96 kN)
8"	0.188" Wall Sch. 40				

- 1) Brace Angles are determined from Vertical.
- 2) Sch. 10 Load Ratings may be used for any thicker wall pipe of the same diameter.
- 3) Listed load ratings reduced for angle ranges in accordance with NFPA 13–2019 Table 18.5.2.3.
- 4) Load Ratings reflect 1" (DN25) – 1¼" (DN32) brace members. See table below for listed brace members.
- 5) Minimum safety factor of 2.2 in accordance with NFPA 13–2019 Section A.18.5.2.3.

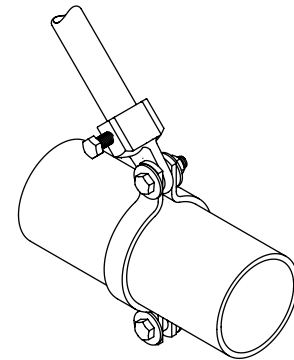

Longitudinal Application

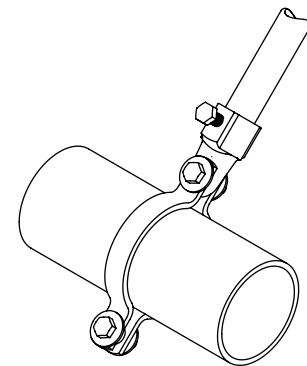

Lateral Application

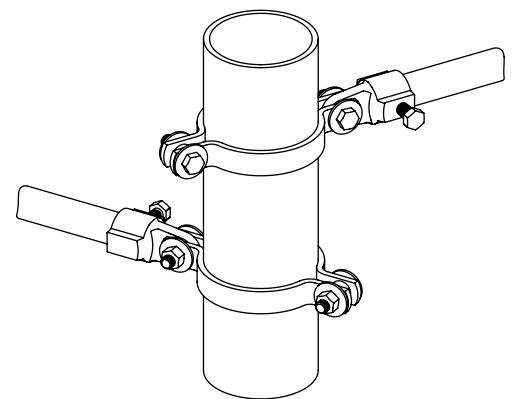

Riser Application



asc-es.com

Building connections that last™

Longitudinal & Lateral Seismic Clamp Fig. AF775

FIG. AF775 FM Approved (Listing) per FM 1950-13 (ASD)

Service Pipe Size	Service Pipe	Longitudinal & Lateral Horizontal Load Rating at Brace Angle				Lateral Load Rating			
		30°- 44°	45°- 59°	60°- 74°	75°- 90°	30°- 44°	45°- 59°	60°- 74°	75°- 90°
2½" (DN65)	LW ² Sch. 10 Sch. 40 Metric Pipe	940 lbf (4.18 kN)	1140 lbf (5.07 kN)	1370 lbf (6.09 kN)	1530 lbf (6.81 kN)	1730 lbf (7.70 kN)	2460 lbf (10.94 kN)	3010 lbf (13.39 kN)	3360 lbf (14.95 kN)
3" (DN80)	LW ² Sch. 10 Sch. 40 Metric Pipe								
4" (DN100)	LW ² Sch. 10 Sch. 40 Metric Pipe	780 lbf (3.47 kN)	920 lbf (4.09 kN)	1190 lbf (5.29 kN)	1080 lbf (4.80 kN)	1140 lbf (5.07 kN)	1610 lbf (7.16 kN)	1970 lbf (8.76 kN)	2200 lbf (9.79 kN)
5" (DN125)	LW ² Sch. 10 Sch. 40 Metric Pipe								
6" (DN150)	LW ² Sch. 10 Sch. 40 Metric Pipe	1000 lbf (4.45 kN)	1260 lbf (5.60 kN)	1280 lbf (5.69 kN)	1410 lbf (6.27 kN)	1360 lbf (6.05 kN)	1920 lbf (8.54 kN)	2350 lbf (10.45 kN)	2620 lbf (11.65 kN)
8" (DN200)	Sch. 10 Sch. 40 Metric Pipe	830 lbf (3.69 kN)	1140 lbf (5.07 kN)	1330 lbf (5.92 kN)	1470 lbf (6.54 kN)	1380 lbf (6.14 kN)	1960 lbf (8.72 kN)	2400 lbf (10.68 kN)	2680 lbf (11.92 kN)

- 1) Brace Angles are determined from Vertical.
- 2) LW Refers to FM Approved Lightwall pipe, commonly referred to as Sch. 7 and Flow Pipe. See FM Approval Guide for approved Lightwall pipe.
- 3) Sch. 10 & 0.188" Wall Load Ratings may be used for any thicker wall pipe of the same diameter.
- 4) See table below for FM listed specialty pipes & FM Listed metric service pipes.
- 5) Load Ratings reflect 1" (DN25) - 1¼" (DN32) brace members. See table below for listed brace members.
- 6) Minimum safety factor of 1.5 in accordance with NFPA 13-2016 Section A.9.3.5.2.3. To convert the load ratings above to a safety factor of 2.2 per NFPA 13-2019 Section A.18.5.2.3, multiply load ratings by a factor of 0.68.
- 7) To convert to LRFD Load Ratings, ASD Load Ratings may be multiplied by a factor of 1.5.

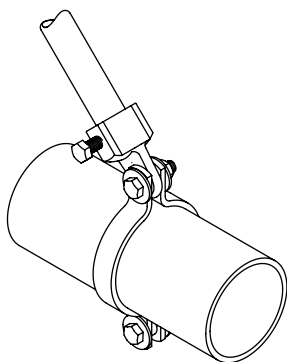

Longitudinal Application

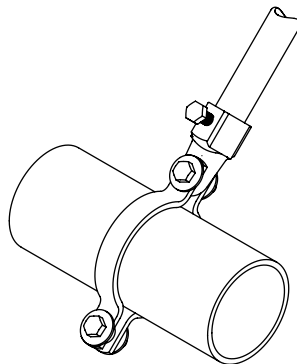

Lateral Application

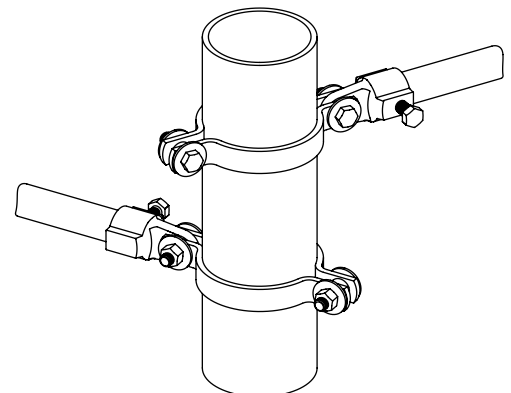

Riser Application



asc-es.com

Building connections that last™

Longitudinal & Lateral Seismic Clamp Fig. AF775

- 1 Position the clamp at the desired location on the service pipe and hand tighten the hex bolts. Ensure the spacers and the brace socket attachment are positioned on the bolt between the pipe clamps ears.
- 2 Insert brace pipe into the socket until the brace pipe bottoms out..
- 3 Torque set screw until the head breaks off.
- 4 Ensure the brace angle is within the specified range.
- 5 Tighten the clamp bolts and nuts equally and alternately until metal to metal contact is achieved with the proper torque value.

FIG. AF775 cULus Listed & FM Approved Brace Members

Brace Member	Sizes	Standards (or Equivalent)	UL Listed	FM Approved
Sch. 40 NPS Pipe	1", 1¼"	ASTM A53, A106, A135, or A795	✓	✓
Sch. 40 Metric Pipe		KS D 3562	✓	✓
Metric Pipe	DN25 DN32	EN10255H		✓
		GB/T 3091		✓
		JIS G3454		✓

FIG. AF775 cULus Listed & FM Approved Metric Service Pipes

Service Pipe Sizes (or Equivalent)	Service Pipe Sizes	UL Listed	FM Approved
KS D 3507 KS D 3537		✓	✓
KS D 3562 Sch. 40		✓	✓
GB/T 3091 GB/T 3092	DN65 DN80 DN100		✓
JIS G3452	DN125 DN150 DN200		✓
EN 10255M			✓
EN 10255H			✓

Notes:

ASC Engineered Solutions™ brand bracing components are designed to be compatible ONLY with other ASC Engineered Solutions brand bracing components, resulting in a Listed seismic bracing assembly. Updated UL listing information may be viewed at www.ul.com and updated FM approval information may be viewed at www.approval-guide.com.

Disclaimer:

ASC Engineered Solutions™ does not provide any warranties and specifically disclaims any liability whatsoever with respect to ASC bracing products and components that are used in combination with products, parts or systems not manufactured or sold by ASC. In no event shall ASC be liable for any incidental, direct, consequential, special or indirect damages or lost profits where non-ASC bracing components have been, or are used.

Seis Brace® Seismic Fire Protection Design Tool may be accessed at www.seisbrace.com



asc-es.com

Building connections that last™